

viccarbe

Burin

Designed by Patricia Urquiola

Technical info - EN

HEIGHT 74 | 29³/₄"

BUD60_
table round 60 | 23⁵/₈"



HEIGHT 74 | 29³/₄"

BUD80_
table round 80 | 31¹/₂"

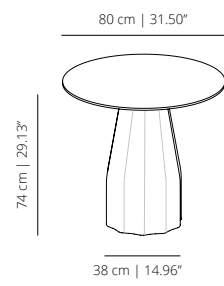

HEIGHT 74 | 29³/₄"

BUD120_
table round 120 | 47¹/₄"

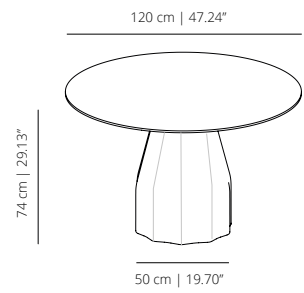

BUD70_
table round 70 | 27⁶/₁₆"

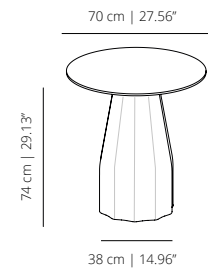

BUD100_
table round 100 | 39³/₈"

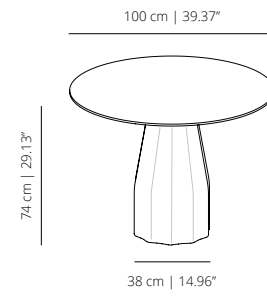

BUD150_
table round 150 | 59¹/₁₆"

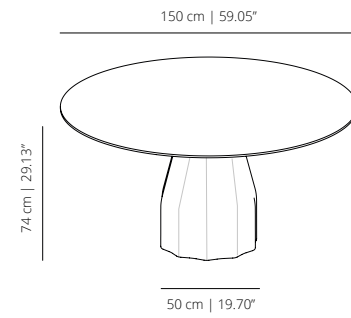

HEIGHT 74 | 29³/₄"

BUC70_
table 70x70 | 27⁶/₁₆" x 27⁶/₁₆"

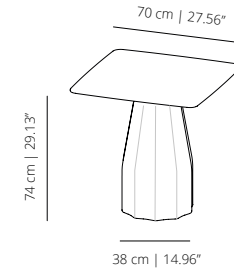

HEIGHT 74 | 29³/₄"

BUC90_
table 90x90 | 35⁷/₁₆" x 35⁷/₁₆"

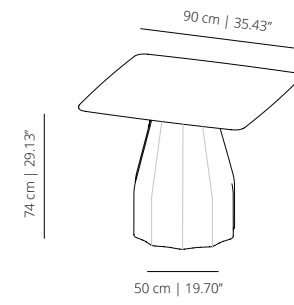

HEIGHT 74 | 29³/₄"

BUC240_
table 240x120 | 94¹/₂" x 47¹/₄"

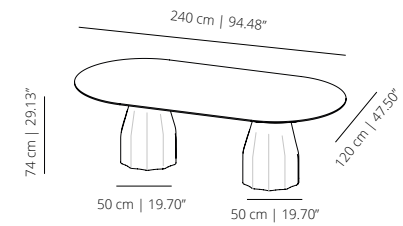

BUC80_
table 80x80 | 31¹/₂" x 31¹/₂"

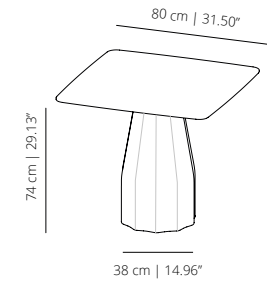

BUC100_
table 100x100 | 39.37" x 39.37"

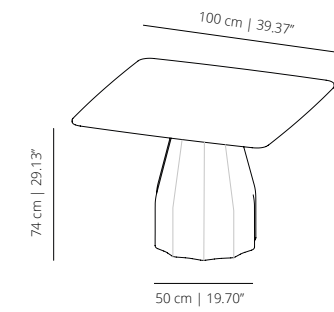

BUC300_
table 240x120 | 118⁷/₆₄" x 59¹/₁₆"

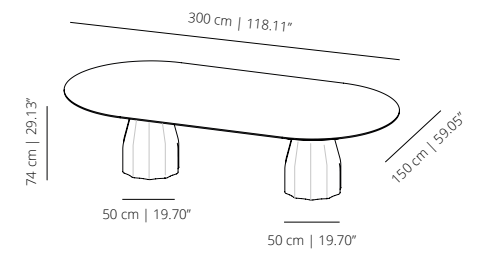

HEIGHT 74 | 29³/₁₆

BUC500_
table 500x150 | 196²⁷/₃₂ x 59¹/₁₆

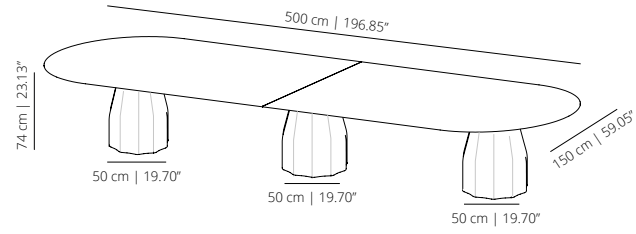

HEIGHT 102 | 40³/₁₆

BUD60H_
table round 60 | 23⁵/₈

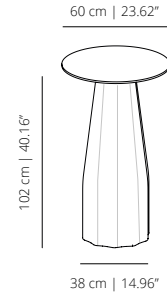

HEIGHT 102 | 40³/₁₆

BUC80H_
table 80x80 | 31¹/₂ x 31¹/₂

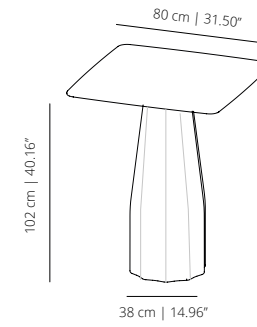

HEIGHT 102 | 40³/₁₆

BUD70H_
table round 70 | 27⁶/₁₆

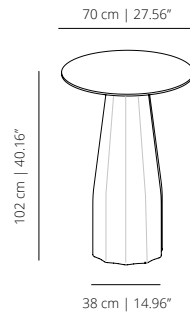

BUD80H_
table round 80 | 31¹/₂

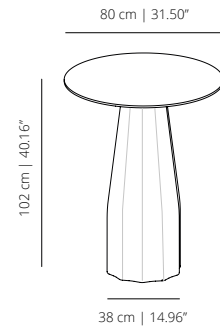

HEIGHT 102 | 40³/₁₆

BUD100H_
table round 100 | 39³/₈

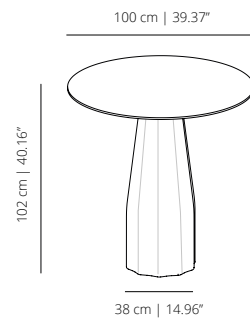

BUC70H_
table 70x70 | 27⁶/₁₆ x 27⁶/₁₆

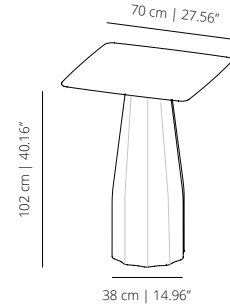

SEATING CAPACITY

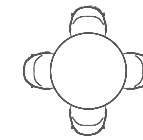

Up to 4
D60 - D100 cm | D23.6\" - D39.4\"

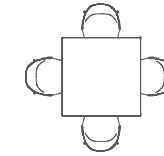

Up to 4
70x70 - 100x100 cm | 27.6x27.6\" - 39.4x39.4\"

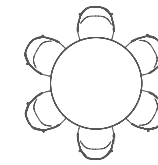

Up to 6
D120 cm | D47.24\"

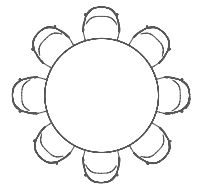

Up to 8
D150 cm | D59\"

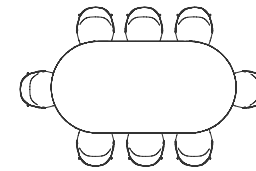

Up to 8
240x120 cm | 94.5x47.24\"

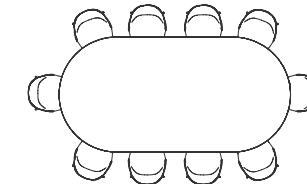

Up to 10
300x150 cm | 118.1x59.1\"

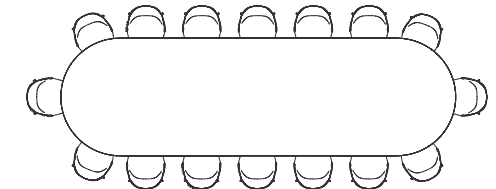

Up to 16
500x150 cm | 196.85x59.1\"

**Seats calculated using Aleta chair, might differ when choosing other models*

TABLETOPS MATERIALS

MDF - STAINED & LACQUERED

The 30 mm thick cover or work surface is made with microtextured MDF. It is lacquered with one of our collection's finishes. It also comes with a solid oak veneer, stained in mate, cognac or ash. Available in high resistance materials such as HPL with MDF for heavy contract use.

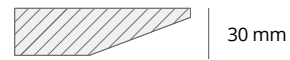

30 mm



bleached stained oak matt stained oak cognac stained oak walnut stained oak ash stained oak



white RAL 9003 black RAL 9005 taupe RAL 1019 dusty green RAL 7034 olive green RAL 0904030 brick RAL 0505030 dusty pink RAL 0607020

HPL WITH MDF

High pressure HPL laminate in black or white on a 30 mm thick MDF board with stained edges in transparent.

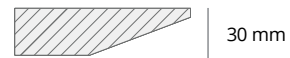

30 mm



black white black white

MELAMINE

Melamine (LPL) thickness 19 mm with 1,5 mm PVC edge, in black or white.



19 mm

COMPACT

12 mm thick compact laminated table top. The edge can be in black or white. With a black edge, the surface of the tabletop can be black or white; for a white edge, it can be white.



12 mm



black white

BASE OPTIONS

Central support available in roto-moulded polyethylene in white, black or taupe.



white RAL 9003 black RAL 9005 taupe RAL 1019

Heights and types of bases available:

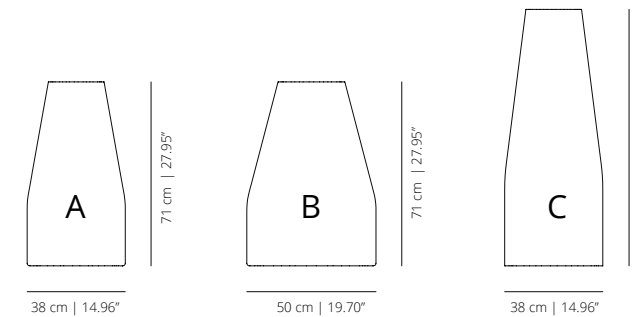

Range of tops for base A: D60 - D100 | 60x60 - 80x80
 D23.62" - D39.37" | 23.62"x23.62" - 31.49"x 31.49"
 Range of tops for base B: D120 - D150 | 90x90 - 100x100 - 140x140
 D47.24" - D59.05" | 39.37"x39.37" - 55.11"x55.11"
 Range of tops for base C: D60 - D100 | 70x70 - 80x80
 D23.62" - D39.37" | 27.55"x27.55" - 31.49"x 31.49"

Different electrification options:

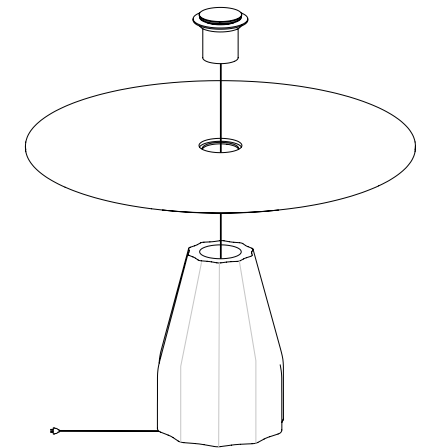

OUTDOOR FINISHES

TABLETOPS MATERIALS

COMPACT

12 mm thick compact laminated table top. The edge can be in black or white. With a black edge, the surface of the tabletop can be black or white; for a white edge, it can be white.



12 mm



black

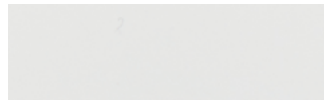

white

BASE OPTIONS

Central support available in roto-moulded polyethylene in white, black or taupe.



white
RAL 9003



black
RAL 9005



taupe
RAL 1019

NOTE: Outdoor cover available to protect the product from water, humidity and sunlight.

ACCESSORIES & ELECTRIFICATIONS



Cut out. Table top custom cut out.



Table top protector in eco leather. Metallic hatch access to the lower part of the table. Available in white, black or grey. Does not include power options. Dimensions: 32x15 cm | 12.59"x5.90".



Rectangular conduit. Metallic hatch access to the lower part of the table for wooden table tops. Metal frame available in black or grey and central part in the veneer of the finish of the table. Does not include power options. Dimensions: 32x15 cm | 12.59"x5.90"



Table top hatch powerbox. Metallic hatch with 4 sockets or combined with built-in multimedia devices. Available in white, black or grey. Dimensions: 32x15 cm | 12.59"x5.90"



Power box for table top plus. Metallic hatch with 4 sockets or combined with built-in multimedia devices. Available in white, black or grey. Dimensions: 32x15 cm | 12.59"x5.90"



USB hub with battery. USB hub with two USB device charging ports without being plugged into electric current. It's needed to buy the battery charging tray to charge the USB hub battery.



USB port. Built-in USB hub for charging electronic devices. Available in black or white. Dimensions: Ø 3 cm | 1.18"



Under table powerbox. Powerbox available with 2 sockets or combined with built-in multimedia devices.



Pop-up sockets. Built-in pop-up socket cylinder made of stainless steel can have 2 Schuko sockets or 1 Schuko socket + 2 USB hubs. For different configurations, contact the sales department. The cylinder is hidden and pops up by gently pressing on it, offering the possibility of connection on four sides.

viccarbe

Burin

Designed by Patricia Urquiola

Catalogue - EN

V01

2018



Patricia Urquiola

Patricia Urquiola was born in Oviedo (Spain) and currently lives and works in Milan.

She graduated from the Faculty of Architecture at the Technical University of Madrid in 1989, after completing a thesis with Achille Castiglioni. From 1990 to 1992, she was assistant lecturer to both Achille Castiglioni and Eugenio Bettinelli at the Milan Polytechnic and the E.N.S.C.I. in Paris.

She is currently working in her own practice in Milan in the fields of design, exhibitions, art direction and architecture. Patricia Urquiola works for Alessi, B&B, Kartell, Molteni, Moroso, Coalesse and VICCARBE.

BURIN

Shape & character

Table designed by Patricia Urquiola, 2018

“There is a fine line between the ambition to achieve iconic design and functional design at the same time, a line between the personality of the author and the role that a table should play in a collective or private space.”

The rules of the game are broken. The boundaries between spaces are blurred. What in the past we were used to understand as work spaces, today have become friendly living rooms or quiet libraries.

The reference boutique hotels and cafés want to be co-working spaces. Households prepare for co-living. And—above all—they take values such as flexibility for granted.

But in all these spaces, in all these places for people, there is a value sine qua non to the condition of the human being. In all of them there is the search for well-being, self-realization and freedom of expression. In all of them, one expects to experience the feeling of comfort. There is therefore a fine line between

the ambition to achieve iconic design and functional design at the same time, a line between the personality of the author and the role that a table should play in a collective or private space.

With Patricia Urquiola, we learned to look for new ways of constructing, to make use of materials that the classic furniture industry would not have contemplated. We also learned to project a continuity within the collection. In Burin's case, it would happen at the time when we were expanding an existing family, but also with the use of rotational polyethylene in the manufacture of its base. The moment when we opened the doors to this material comes to mind: 2006 gave us the Last Minute stool and its seat in this same rotomolded polyethylene.



On this page set of a Burin table with matt oak table top and black base with Maarten Plastic chairs, sled base

DOUBLE BURIN

It is fascinating how the use of an unusual component has managed to democratize this centrally based table. However, above all, it is interesting how it has happened without losing an ounce of character and differentiation. By giving the possibility of combining its base with more sophisticated boards, we manage to maintain the balance that is created between durability and elegance, no matter if it is in its single, double or triple base version.



On this page, a set of a double Burin table lacquered in black with Quadra chairs in ash



SUBTLE CONNECTIVITY

Additionally, Burin can include electrification systems in a discreet and fully integrated manner, an extra dose of functionality and aesthetics for meeting spaces and large conference rooms.

On the left page, a set of a Burin table lacquered in black with Copa cantilever chairs. On this page, a Burin triple table in black finish with Maarten Plastic chairs, pyramid base and brick seats

An environmentally



friendly process

Rarely does the industrial process of a design make big headlines. However, from the perspective of sustainability, this is precisely the benefit of a design. Industrialization has given us the possibility to make life easier for society and to share our Mediterranean lifestyle. It has opened the door to innovative product categories capable of responding to new contexts, behaviors and moments with the best designers and architects in the world. We learned about artisan processes but, over the years, we found the opportunity to evolve to find ways to create that are more efficient and sustainable over time, ways which are more respectful of the environment.

In the case of Burin, its base is made through a mold in which the pellets are rotated and gradually molded into a base that will later not only be resistant and durable over time for decades, but also totally recyclable. Beauty is, without a doubt, on the inside.

Pictures during the manufacturing process of a Burin table



Burin & Food

Restaurants — Thanks to its base, Burin is a table especially suitable for *hospitality* spaces: hotels, bistros, cafés... It is easy to clean and very resistant to the course of time.



In these pages, a picture of Burin tables with square matt oak table top and taupe base combined with four-legged wooden Copa chairs



Project on the left page: HudCo Coworking Space, New York.
Design: Christina Michelle Interiors.
Photography: Ball & Albanese



Project on the right page: Club Alma Sensai, Madrid
Interior design: Mar Vera para Welcome Design
Photography: Paloma Pacheco Turnes







In these pages, a picture of Burin table with Aleta chairs

Burin table & Burin Mini



Burin H74 70x70 cm /
H29.13" 27.56"x27.56"



Burin H74 80x80 cm /
H29.13" 31.50"x31.50"



Burin H74 D70 cm /
H29.13" D27.56"



Burin H74 D120 cm /
H29.13" D47.24"



Burin H102 80x80 cm /
H40.16" 31.50"x31.50"



Burin H102 D80 cm /
H40.16" D31.50"



Burin H74 100x100 cm /
H29.13" 39.37"x39.37"



Burin Mini H50 - H55 cm /
H19.69" - H21.95"



Burin Mini H50 + 10 cm (handle) /
H19.69 + 3.94" (handle)

Burin table



Burin double base H74 L240 cm / H29.13" L94.48"
with powerbox



Burin double base H74 L240 cm / H29.13" L94.48"



Burin central base H74 D150 cm / H29.13" D59.05"
with pop-up sockets



Burin triple base H74 L350 cm / H29.13" L889"
with pop-up sockets

Connectivity



1. Pop-up sockets
2. USB port
3. Powerbox
4. Pop-up sockets

New
COLLABORATIVE
OUTDOOR

Talking about outdoor furniture is talking about collaboration. Nature inspires us to connect, dream and create. Nature brings us back to our roots. The natural light invites us to make the exterior stage the meeting point of all the celebrations and reunions, the place to share and cooperate. We are increasingly committed to creating outdoor spaces with natural textures and raw materials that transmit serenity and harmony. Places to live, feel and enjoy.

Shortly, our latest launch will see the light of day: Viccarbe Collaborative Outdoor. A line of flexible furniture, for use both in and outdoor, that takes geometry and nature as a reference. Noble materials that endure over time and invite you to connect with the outside and make it an extension of the office. A place to get inspired and let creativity flow. Mediterranean essence in all its splendor. Coming very soon to Viccarbe.

COMING SOON TO VICCARBE



Let's talk

We want to help you find the best designs for your project. Contact us and our team will get back to you as soon as possible.

[CONTACT US](#)